

This is an Accepted Manuscript version of the following article, accepted for publication in:

P. Madina, J. Poza, G. Ugalde and G. Almandoz, "Analysis of non-uniform circumferential segmentation of magnets to reduce eddy-current losses in SPMSM machines," 2012 XXth International Conference on Electrical Machines, 2012, pp. 79-84.

DOI: <https://doi.org/10.1109/ICEIMach.2012.6349843>

© 2012 IEEE. Personal use of this material is permitted. Permission from IEEE must be obtained for all other uses, in any current or future media, including reprinting/republishing this material for advertising or promotional purposes, creating new collective works, for resale or redistribution to servers or lists, or reuse of any copyrighted component of this work in other works.

Analysis of non-uniform circumferential segmentation of magnets to reduce Eddy-current losses in SPMSM machines

Patxi Madina, Javier Poza, Gaizka Ugalde, Gaizka Almandoz
FACULTY OF ENGINEERING, UNIVERSITY OF MONDRAGON
Loramendi 4
20500 Mondragon, Spain
Tel.: +34 943 794700
E-Mail: pmadina@mondragon.edu
URL: <http://www.mondragon.edu/enele>

Abstract – Eddy current losses generated in the rotor of the permanent magnet machines may lead to an excessive magnet heating. This can cause full demagnetization of the magnets so it is very important to analyze the losses on them to adopt solutions to reduce eddy current losses. The most common technique is the magnet circumferential segmentation. The segmentation of the magnetic poles usually is the same for each magnet segment. In this paper a new concept named non-uniform magnet segmentation is presented, where the length of each segment of a pole is chosen to minimize the losses. This method is tested in three different machines with particular characteristics and the results confirm that fewer losses can be achieved with this segmentation technique.

Index Terms—AC machines, Demagnetization, Eddy currents, Finite element methods, Magnetic losses, Permanent magnet machines, Permanent magnets, Rotating machines, Temperature

I. INTRODUCTION

PERMANENT magnet (PM) machines have been increasingly used in a wide variety of applications such as train traction, elevation, electric and hybrid vehicle or power generation [1-3]. Until now, in such applications where a high power is desired, induction machines (IM) have been preferred due to their great robustness. But with the latest trends in energy efficiency, a technological leap towards permanent magnet synchronous motors (PMSM) has been stimulated, due to their high power density and efficiency. However, the use of magnets involves taking into account the thermal behavior of the rotor, because a high temperature in the magnet reduces its performance and increases the risk of magnet demagnetization. There are two main heating sources as far as the magnets are concerned. The magnets are heated due to the hot components of the machine (stator core, stator winding). In addition, the magnets are exposed to a time varying magnetic field which induces eddy current (EC) losses on them due to the magnetic field of the stator currents. Even though these rotor losses are not in general an efficiency problem, they can lead to magnet overheating. A high temperature reduces the magnet performance and increases the risk of magnet

demagnetization. Therefore, it is important to understand the causes of EC losses in the magnets.

The EC losses in surface mounted permanent magnet synchronous machines (SPMSM) can be resistance limited [4-10], or not-resistance limited [11], [12]. The resistance limited ECs are characterized by low frequency components which lead to typically a uniform distribution of the losses across the radial axe of the magnet. In other words, the losses are not induced in a skin depth due to the low frequency of the harmonics which induce the losses. The opposite case is the non resistance limited EC losses. In this case the losses are induced in a narrow area of the magnets (skin depth) due to the high frequency harmonics involved in the ECs induction.

In this study, only resistance limited losses will be considered. In the literature, the resistance limited EC losses are studied either analytically [10], [5;6;8], [13], which may lead to some inaccuracies because they do not take into account the non-linearity effects of the BH curve of the stator and rotor core, or by finite element analysis (FEM) [14-17]. In this case, the results are more accurate, but computation may be quite time-consuming. Moreover, the FEM analysis time increases even more when loss reduction mechanisms such as segmentation are analyzed. A fast design tool for the correct segment number selection is desirable for a rapid machine design.

The method developed in [18] combines FEM model with existing analytical tools achieving a PM losses calculation method that considers the non linear BH curve of the magnetic steel and makes possible to analyze the effect of different magnet segmentations [7], [10] in a fast and precise way.

Using this mixed technique, this paper analyzes a new segmentation technique with different magnet length for each segment. All the magnetic poles have the same number of segments and the distribution of the segments is equal too.

The reduction of permanent magnet losses is analyzed comparing it to the uniform magnet segmentation to study the goodness of this segmentation technique.

II. ANALYZED MACHINES

Three different machines have been analyzed so as to study effect of non-uniform segmentation in the reduction of losses. All of them are SPMSM. Their main features are shown in the following table:

TABLE I
CHARACTERISTICS OF THE STUDIED MACHINES

Phases	3 phases	3 phases	3 phases
Nominal Power	157,3KW	143,6KW	143,6KW
Poles (2p)	6 poles	14poles	14poles
Number of slots (Q)	36	42	18
Turns per phase	30	42	42
Frequency	89,4Hz	200Hz	200Hz
Rated Current	245Aeff	175Aeff	175Aeff
Slots per pole per phase	2	1	0.4286

As it can be seen, two of the machines are integer slot machines (integer number of slots per phase per pole), the first one having 3 pole pairs and the second one 7 pole pairs. The second machine under study, has greater frequency and lower current than the first one. Both of them have distributed windings. The last machine is almost identical to the second one in every aspect, but in this case, it is a fractional-slot concentrated winding machine.

This way, the influence of factors such as frequency, current level, number of pole pairs and winding type, can be taken into account. An ideal sinusoidal current has been used in all three cases.

The three machines are depicted in Fig. 1, Fig. 2 and Fig. 3 respectively.

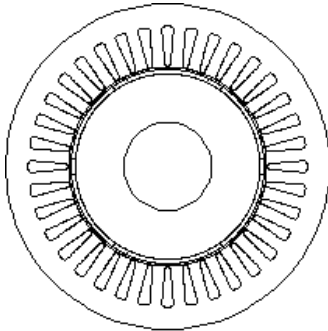

Fig. 1 Capture of the 3 pole pair 36 slot integer machine

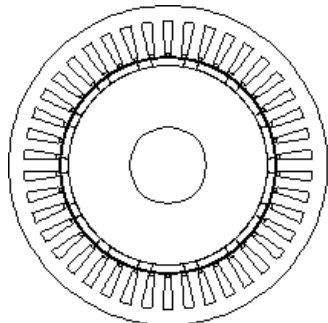

Fig. 2 Capture of the 7 pole pair 42 slot integer machine

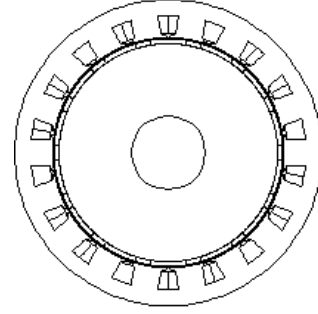

Fig. 3 Capture of the 7 pole pair 18 slot fractional machine

As for the magnets, all three machines employ the same type of permanent magnets. Their characteristics are shown in the table below.

TABLE II
ATTRIBUTES OF THE EMPLOYED PERMANENT MAGNETS

Type	Ne-Fe-B
B_r	1.1T
μ_r	1.09
ρ	$1,47 \cdot 10^{-6} \Omega \cdot m$

III. MAGNET LOSSES CALCULATION METHOD

The goal is to study different segmentations for each machine, and for each segmentation, multiple magnet length configurations.

If multiple segmentation possibilities are going to be analyzed with FEM precision, the time consumption may be too elevated. Each configuration requires:

- Geometrical definition
- FEM simulation
- Acquisition of results

With the purpose of reducing the calculation time drastically, the method explained on [18] has been employed to calculate the losses generated in the permanent magnets due to the induced currents caused by the armature field.

This method only requires one FEM simulation for each machine that is going to be analyzed. From that simulation, the flux density at a certain radius of the magnet as a function of time is obtained. From there, the losses are calculated analytically with a high precision and short time consumption.

The method assumes that the magnet depth is small enough to consider the flux density constant in the radial direction of the magnet. Moreover, the method does not consider the EC end effects in the magnets.

With this consideration, first the induced eddy-current density in the permanent magnet arc segments is obtained. This is done by solving the following equation:

$$J_m(t, \theta) = -\frac{1}{\rho} \cdot \int \frac{\partial B(t, \theta)}{\partial t} \cdot r \, d\theta + C \quad (1)$$

Where ρ is the electrical resistivity of the PMs, θ is the magnet arc, r is the radius and C is an integration constant which ensures zero net total current flow in each magnet segment at any instant:

$$\int J_m \cdot r \, d\theta = 0 \quad (2)$$

Finally, the power losses per segment are obtained from the following equation:

$$P = \frac{L}{T} \cdot \int_0^T \int_{\alpha_1}^{\alpha_2} \int_{R_1}^{R_2} \rho \cdot Jm^2 r dr d\theta dt \quad (3)$$

Where L is the machine axial length and T is the time period, α_1 and α_2 are the magnet segment arc limits and R_1 and R_2 are the inner and outer radius of the magnet.

In this way, with only one 2D FEM simulation, we can calculate the permanent magnet losses for any magnet circumferential segmentation with a considerably good accuracy. Repeating the computation for a large amount of segmentation possibilities the best solution can be obtained.

IV. RESULTS

Once the machines are designed, the finite element software Flux2D has been employed to carry out the simulations for obtaining the magnetic field in the magnets.

After that, by applying the equations showed above, several segmentations have been tested, starting with uniform circumferential segmentation and then, trying every segment length combination, so that an optimum segment length is obtained for certain segment numbers.

A. Uniform circumferential segmentation

In the following, the magnet Eddy-Current losses of the three machines for different segmentation levels are shown.

In the case of the 3 pole pair integer machine, the magnets are segmented from 1 to 16 segments per pole.

In the other two cases, instead, they have only been divided from 1 to 10 segments, as the poles are smaller, due to the high pole number of the machine.

The limit of segments is related to the length of the segments, being too narrow if the number is increased. This would make the machine mechanically difficult to construct.

The circumferential segmentation is known to reduce the EC losses induced in the magnets, but its effects can be different depending on the characteristics of the machines.

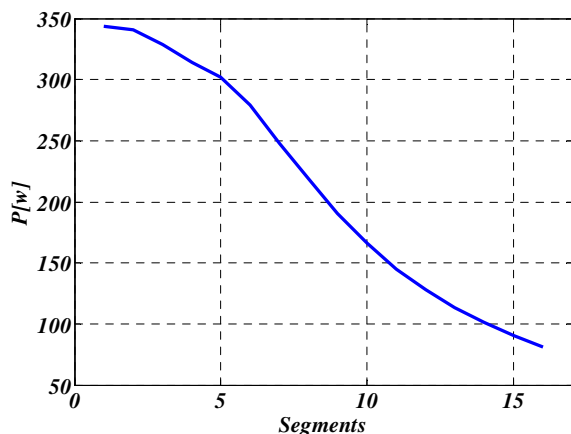

Fig. 4 Magnet EC losses for different segmentation levels on the 3 pole pair 36 slot integer machine

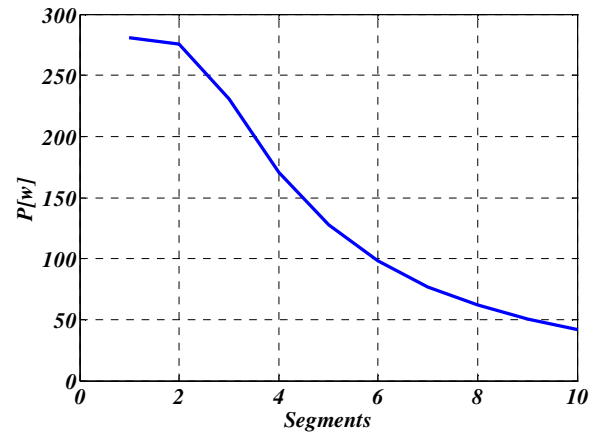

Fig. 5 Magnet EC losses for different segmentation levels on the 7 pole pair 42 slot integer machine

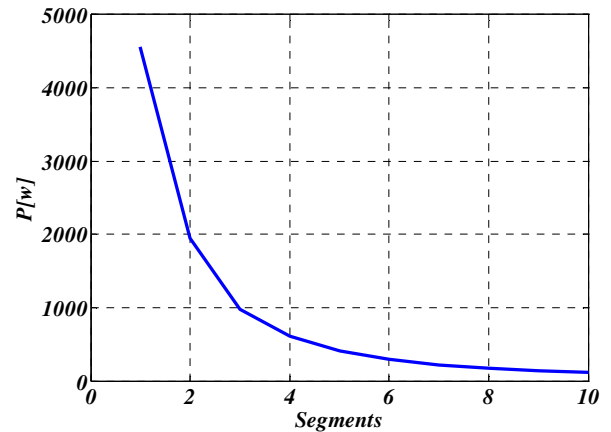

Fig. 6 Magnet EC losses for different segmentation levels on the 7 pole pair 18 slot fractional machine

The first thing that can be noticed in the previous figures is that the losses are relatively higher in the case of the fractional slot machines. This is due to its higher content of spatial harmonics. In this case, there are sub-harmonics as the component of the winding factor that generates the fundamental component of the electromagnetic torque is the 7th.

Other than that, the losses reduction is a lot more significant in this machine, being the losses when two segments are employed less than the half of those with only one segment.

However, in the integer machines, the losses are reduced almost linearly as the segment number increases, whilst in the fractional one, once the number of 5 segments is reached, the loss reduction is not so important if compared to the reduction achieved using up to 4 segments.

B. Non-uniform circumferential segmentation

In this study, an algorithm has been employed, so that the segment length is varied and an optimum segmentation is found for any number of segments. In this case, segmentations of 2, 3, 4 and 5 segments have been studied. As the segment number increases, the number of possible combinations raises almost exponentially and so does the computation time.

Starting with the 2-segment configuration, the length of the first segment of has been varied, from being very narrow to filling almost the whole pole. The losses have been computed and they are shown in the following three figures,

being the abscissa axis the length of this segment in per-unit system with respect to the total length of the magnetic pole with one segment. Thus, a length of 0,5 pu, would mean that the poles are segmented evenly.

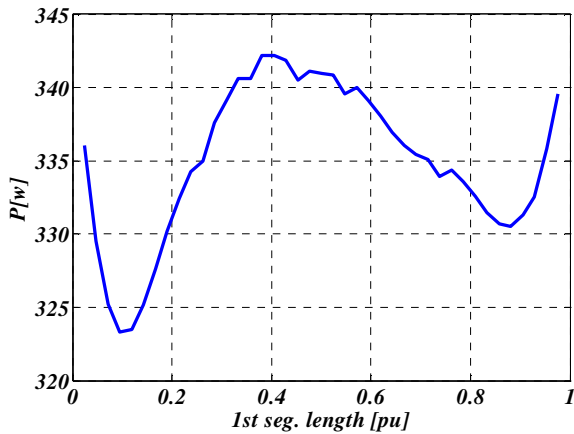

Fig. 7 Magnet EC losses for different segment length in a 2-segment configuration on the 3 pole pair 36 slot integer machine

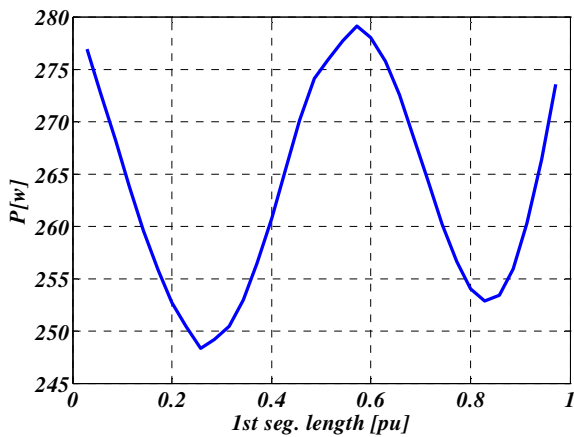

Fig. 8 Magnet EC losses for different segment length in a 2-segment configuration on the 7 pole pair 42 slot integer machine

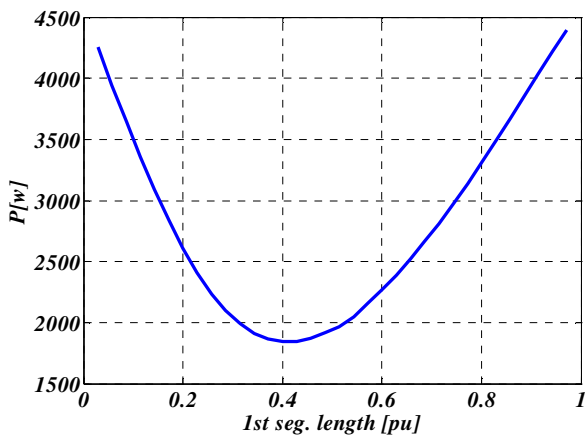

Fig. 9 Magnet EC losses for different segment length in a 2-segment configuration on the 7 pole pair 18 slot fractional machine

As it can be seen, in the integer slot machines, the optimum is achieved when the first segment is considerably smaller than the second one, while in the third machine, the losses reach their minimum when both segments are almost equal. In the case of the integer machines, a segment length of 0.5 pu gives a high value of losses, almost reaching the maximum value for that segment number.

In Fig. 10 the optimal segment lengths are graphically shown for the three machines.

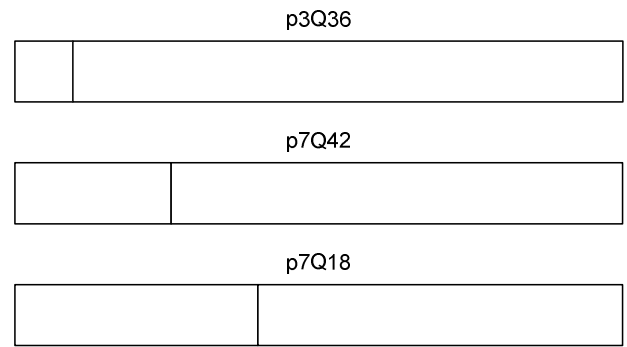

Fig. 10 Optimal two-segment segmentation for the three analyzed machines

The same thing has been done for the case of three-segment poles.

In this case, the configuration for the minimum magnet losses in each machine has been registered. The results are graphically shown in Fig. 11.

Again, for the integer machines, the first two segments are clearly shorter than the third one, while in the fractional machine the length of each segment is virtually the same.

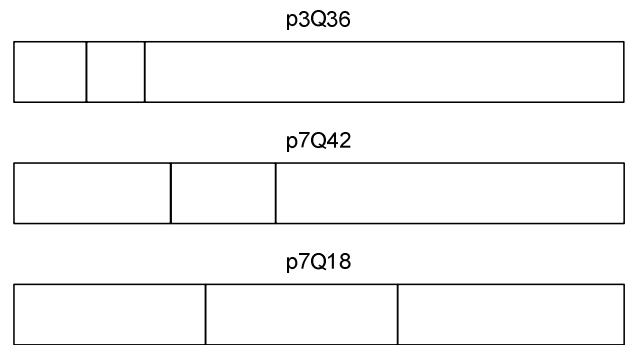

Fig. 11 Optimal three-segment segmentation for the three analyzed machines

In the case of four-segment poles, as it can be observed in Fig. 12, the 7 pole pair machines need a configuration with almost equal segments, while in the 3 pole pair machine the first segment is visibly bigger than the rest of them.

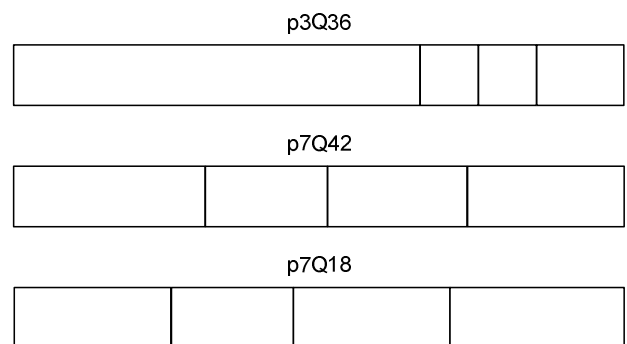

Fig. 12 Optimal four-segment segmentation for the three analyzed machines

Finally, the best segment length combination for five-segment poles has been analyzed. In this case, the results are similar to those of the four-segment poles. The first segment of the 3 pole machine has to be a lot bigger than the rest to accomplish the optimum. In the other two machines though, the optimum is achieved with the segments being almost equal.

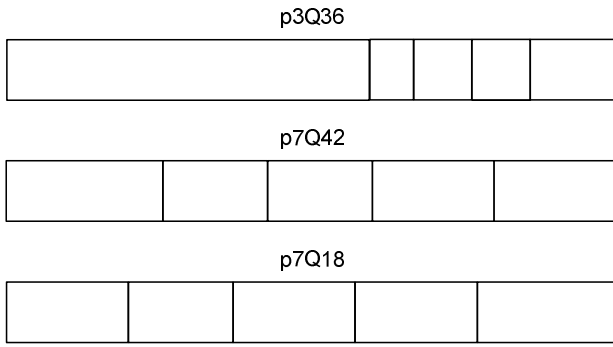

Fig. 13 Optimal five-segment segmentation for the three analyzed machines

The magnet EC losses in Watts for the four configurations shown above for each machine are depicted from Fig. 14 to Fig. 16, comparing them to the losses obtained by uniform segmentation, which were obtained on section A.

As it can be seen in the following figures, in all this three machines a loss reduction is possible by employing the non-uniform magnet segmentation on behalf of uniformly segmented poles.

In the 3 pole pair integer machine there are fewer losses with 2 non-uniform segments than with 3 uniform segments. The same happens if 3 non-uniform segments are compared to 4 uniform segments and so on. Thus, fewer losses can be achieved with less segments using non-uniform segmentation.

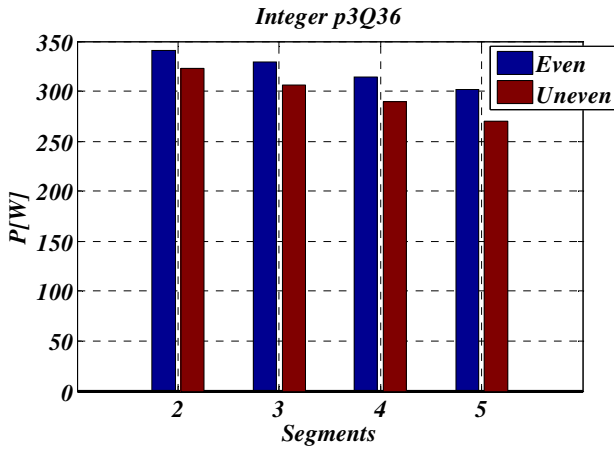

Fig. 14 Magnet EC loss comparison between uniform and non-uniform optimal segmentation in the 3 pole pair 36 slot integer machine

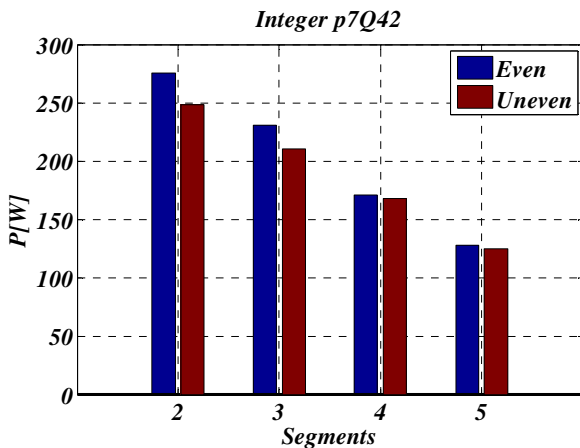

Fig. 15 Magnet EC loss comparison between uniform and non-uniform optimal segmentation in the 7 pole pair 42 slot integer machine

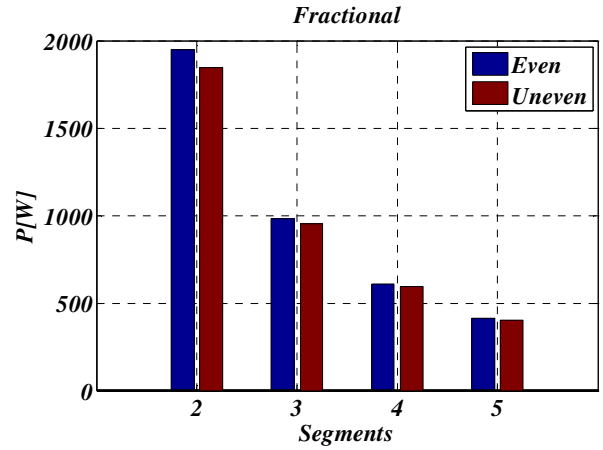

Fig. 16 Magnet EC loss comparison between uniform and non-uniform optimal segmentation in the 7 pole pair 18 slot fractional machine

As can be appreciated, the reduction is clearly more evident in the integer slot machines than on the fractional slot machines.

One of the cases has been verified by a full FEM simulation, specifically the 3 segment optimal configuration of the p3Q36 integer machine, in which the segments happen to be very non-uniform. The table below, where the losses obtained in FEM, analytically and the error are displayed, shows the high accuracy of the method for this particular case.

TABLE III
COMPARISON BETWEEN FEM AND ANALYTICAL METHOD

P_{FEM}	P_{ANALYT}	Error
298 W	306.5 W	2.85%

Finally, the lost reduction percentage when optimal non-uniform segmentation is employed has been obtained from the figures above. This is represented in Fig. 17.

In the case of the 3 pole-pair integer machine, a bigger reduction can be obtained as the segment number increases, reaching a value of almost 11% when 5 segments are employed.

In the 7 pole-pair integer machine, a 10% loss reduction is achieved with 2 non-uniform segments and a 9% with three. With 4 and 5 segments there is not much of a difference.

Finally, in the fractional machine, the improvement does not exceed the 5% in the four studied segmentation levels.

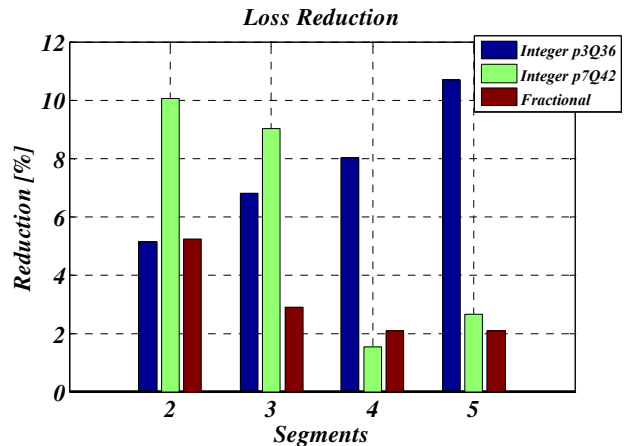

Fig. 17 Magnet EC loss reduction with non-uniform optimal segmentation

V. CONCLUSIONS

To the purpose of reduction of magnet Eddy-current losses in surface mounted permanent magnet machines, the non-uniform magnet circumferential segmentation has been investigated. Magnet poles have been segmented uniformly and also a new concept so-called non-uniform magnet segmentation has been introduced. From the comparison between the classical uniform segmentation and the non-uniform segmentation the goodness of this new technique has been investigated

Three different machines have been used for these tests, two integer machines with different characteristics and a fractional concentrated winding machine, with similar features to one of the integer machines.

The non-uniform magnet circumferential segmentation has been proven to be effective in the reduction of losses in all three machines and especially in the fractional machine.

For four segmentation levels, 2, 3, 4 and 5 segments precisely, every magnet segment length combination has been examined, finding the configuration that minimizes the magnet losses. These non-uniform segment configurations have been found to be more effective in the integer machines, reaching an improvement of more than 10% as far as losses in the magnets is concerned in some of the cases when compared to uniform segmentation.

This enables a reduction in the number of segments handled during assembly. Anyhow, the fabrication and assembly are subjects that should be carefully studied and

VI. REFERENCES

- [1] Takanori Komatsu and Akihiro Daikoku, "Elevator Traction Machine Motors," Japan: Mitsubishi Electric, 2003.
- [2] J. F. Gieras and N. Bianchi, "Electric motors for light traction," *EPE Journal*, vol. 14, no. 1, pp. 12-23, Feb.2004.
- [3] C.Peter Cho, "Permanent Magnet Motors/Generators For Automotive Applications,"2009.
- [4] M. Mirzaei, A. Bänder, and C. Deak, "3D Analysis of Circumferential and Axial Segmentation Effect on Magnet Eddy Current Losses in Permanent Magnet Synchronous Machines with Concentrated Windings," *International Conference on Electrical Machines IECM*, 2010.
- [5] M. Markovic and Y. Perriard, "A simplified determination of the permanent magnet (PM) eddy current losses due to slotting in a PM rotating motor," Wuhan.: 2008, pp. 309-313.
- [6] Z. Q. Zhu, K. Ng, N. Schofield, and D. Howe, "Analytical prediction of rotor eddy current loss in brushless machines equipped with surface-mounted permanent magnets. I. Magnetostatic field model," 2 ed Beijing, China: Int. Acad. Publishers, 2001, pp. 806-809.
- [7] H. Polinder, H. Polinder, and M. J. Hoeijmakers, "Eddy-current losses in the segmented surface-mounted magnets of a PM machine," *Electric Power Applications, IEE Proceedings -*, vol. 146, no. 3, pp. 261-266, 1999.
- [8] W.-Y. Huang, A. Bettayeb, R. Kaczmarek, and J.-C. Vannier, "Optimization of Magnet Segmentation for Reduction of Eddy-Current Losses in Permanent Magnet Synchronous Machine," *IEEE Transactions on energy conversion*, vol. 25, no. 2, pp. 381-387, 2010.
- [9] J. Wang, K. Atallah, R. Chin, W. M. Arshad, and H. Lendenmann, "Rotor Eddy-Current Loss in Permanent-Magnet Brushless AC Machines," *IEEE Transactions on Magnetics*, vol. 46, no. 7, pp. 2701-2707, 2010.
- [10] K. Atallah, D. Howe, P. H. Mellor, and D. A. Stone, "Rotor loss in permanent-magnet brushless AC machines," *Industry Applications, IEEE Transactions on*, vol. 36, no. 6, pp. 1612-1618, 2000.
- [11] Z. Q. Zhu, K. Ng, N. Schofield, and D. Howe, "Analytical prediction of rotor eddy current loss in brushless machines equipped with surface-mounted permanent magnets. II. Accounting for eddy current reaction field," 2 ed Beijing, China: Int. Acad. Publishers, 2001, pp. 810-813.
- [12] Z. Q. Zhu, D. Howe, and C. C. Chan, "Improved analytical model for predicting the magnetic field distribution in brushless

- permanent-magnet machines," *Magnetics, IEEE Transactions on*, vol. 38, no. 1, pp. 229-238, 2002.
- [13] J. D. Ede, K. Atallah, and G. W. Jewell, "Effect of Axial Segmentation of Permanent Magnets on Rotor Loss in Modular Permanent-Magnet Brushless Machines," *IEEE transactions on industry applications*, vol. 43, no. 5 2007.
- [14] P. Rasilo and A. Arkkio, "Modeling the Effect of Inverter Supply on Eddy-Current Losses in Synchronous Machines," *Symposium on Power Electronics, Electrical Drives, Automation and Motion (SPEEDAM)*, pp. 861-865, 2010.
- [15] G. Ugalde, Z. Q. Zhu, J. Poza, and A. Gonzalez, "Analysis of Rotor Eddy Current Loss in Fractional Slot Permanent Magnet Machine," in *International Conference on Electrical Machines (ICEM) Rome: 2010*, pp. 1-6.
- [16] P. Sergeant and A. Van den Bossche, "Segmentation of Magnets to Reduce Losses in Permanent-Magnet Synchronous Machines," *IEEE Transactions on Magnetics*, vol. 44, no. 11, pp. 4409-4412, 2008.
- [17] K. Yoshida, Y. Hita, and K. Kesamaru, "Eddy-Current Loss Analysis in PM of Surface-Mounted-PM SM for Electric Vehicles," in *12th Conference of the Computation of Electromagnetic Fields (COMPUMAG '99) Oct. 1999*, 36 ed USA: IEEE, 2000, pp. 1941-1944.
- [18] P. Madina, J. Poza, G. Ugalde, and G. Almandoz, "Magnet eddy current loss calculation method for segmentation analysis on permanent magnet machines," in *Proceedings of the 2011-14th European Conference on Power Electronics and Applications (EPE 2011)* 2011, pp. 1-9.

VII. BIOGRAPHIES

Patxi Madina was born in Zumarraga, Spain, on December 19, 1985. He received the B. Sc. degree in electrical engineering from the University of Mondragon, Mondragon, Spain, in 2009, where he is currently working toward the Ph.D. degree.

His research interests are in the fields of permanent magnet synchronous machine design, modeling and thermal optimization.

Javier Poza was born in Bergara, Spain, in June 1975. He received the B.Sc. degree in electrical engineering from the University of Mondragon, Mondragon, Spain, in 1999, and the Ph.D. degree in electrical engineering from the InstitutNational Polytechnique de Grenoble, Grenoble, France, in 2003.

In 2002, he joined the Electronics Department, Faculty of Engineering, University of Mondragon, where he is currently an Associate Professor. His current research interests include electrical machines design, modeling, and control. He participated in different research projects in the field of wind energy systems, lift drives, and railway traction.

Gaizka Ugalde received the B.Eng. and Ph.D. degrees in electrical engineering from the University of Mondragon, Mondragon, Spain, in 2006 and 2009, respectively.

In 2009 he joined the Department of Electronics, Faculty of Engineering, University of Mondragon, where he is currently an Associate Professor.

His current research interests include permanent magnet machine design, modeling and control. He has participated in different research projects in the field of lift drives, and railway traction.

Gaizka Almandoz was born in Arantza, Spain, in 1979. He received the degree in electrical engineering from the University of Mondragon, Mondragon, Spain, in 2003, and the Ph.D. degree in electrical engineering the University of Mondragon, Mondragon, Spain, in 2008

In 2003 he joined the Department of Electronics, Faculty of Engineering, University of Mondragon, where he is currently an Associate Professor.

His current research interests include the electrical machine design, modeling and control. He has participated in different research projects in the field of wind energy systems, lift drives, and railway traction.