



Reliability simulation of a multi-state Wind Turbine Generator using SHyFTOO

Soheyl Moheb Khodayee¹, Ludovica Oliveri¹, Jose Ignacio Aizpurua^{2,3}, Diego D'Urso¹ and Ferdinando Chiacchio^{*1}

¹ Dipartimento di Ingegneria Elettrica, Elettronica ed Informatica, Università degli Studi di Catania, Viale Andrea Doria 6, 95125 Catania, Italy.

² Electronics & Computing Department, Mondragon University, Goiru 2, 20500, Ar-rasate-Mondragon (Spain)

³ Ikerbasque, Basque Foundation for Science, Euskadi Plaza 5, Bilbao (Spain)

*Corresponding author. Email chiacchio@dmi.unict.it

Abstract

Accurate reliability analysis modelling requires appropriate stochastic formalisms, which can capture the relevant operation and degradation characteristics of the system under analysis. Physical, working and environmental conditions can be very relevant, but their inclusions in a stochastic model is challenging. Among reliability analysis methodologies, a recent formalism named Hybrid Dynamic Fault Tree, which emerges from dynamic reliability theory, may be a suitable candidate to accomplish in this task. In this paper, a wind turbine generator case study has been chosen to demonstrate the potential capabilities of this modeling approach and motivate the use of this formalism to other practitioners. The main novelty of the proposed model is the integration of the wind speed, an independent exogenous physical variable, as a trigger to modify the parameters of the probability density of failures and the aging of components. The Hybrid Dynamic Fault Tree of the proposed case study has been coded using the SHyFTOO, an easy-to-use library developed under the MATLAB® framework. Achieved results show that the Hybrid Dynamic Fault Tree is a valid formalism that should be used to improve the modelling of a multi-state system when working and operative conditions cannot be disregarded.

Keywords: Dynamic Fault Trees; Monte Carlo Simulation; Matlab Framework; RAMS

1. Introduction

Probability risk assessment (PRA) of a system is crucial activity to ensure the reliability and safety of the analyzed industrial process. The purpose of upkeeping the specified functionality of a product over its mission time is conducted by the discipline of Reliability-Availability-Maintainability-Safety, which is short is called RAMS (Calixto, 2013). Even though “RAM” is performed quantitatively using the proper techniques, the last section “Safety”, and in turn Risk assessment, is performed qualitatively using the techniques like

Hazard and Operability Analysis (HAZOP), “Process Hazard Analysis” (PHA) or “Failure Mode, Effects, and Criticality Analysis” (FMECA). The quantitative study uses modelling techniques like (ii) Fault Tree Analysis (FTA) or Reliability Block Diagrams (RBD) to obtain a quantity pertaining to the ability of an item to perform a required function for a given mission time (Reliability) or a given instant of time over a given mission time (Availability). These models can also depict a state of an item that it can perform a required function when maintenance is performed (Maintainability).



All the above-mentioned models are formed completely based on the knowledge and experience of the expert engineers who study the process. In fact, these models reflect a logical image of the expert judgement to represent the relationships among the system components. The formulation of the qualitative models is completely manual. In the quantitative models, potential hazards and consequences are revealed (Chiacchio et al., 2011), however, the probability of the undesired event is obtained using the quantitative models. To do so, failure probabilities are inserted into the proper models and a simulation method is adopted for the solution, although in large cases, the complexity will make the solution so time consuming that makes the solution impractical. This can require the use of computer-aided system to be feasible.

Fault Trees and Reliability Block Diagrams are easy to solve because of their simple hypotheses: a component can be either in working or failed states, the functioning of each component is independent from the others, and it is assumed that the operation conditions are invariant, in that, there is no change in the degree of functionality because of aging.

With these hypotheses it is possible to adopt a static probability density function (PDF) for each component of the system to model time to failure. In this way, the model can be reduced by using Boolean algebra and logic gates, i.e., AND, OR gates, so as to find the structure function and compute the occurrence probability of the top-event. However, this is far from the real operation and failure logic of industrial systems. The reliability modelling of industrial systems is challenging because they are characterized, not only by the failed or working states, but also by the states representing the degree or percentage of functionality which is reduced by the passage of time which causes aging. As a result, components do affect each other in some working condition hence the PDF cannot be assumed static. Since these features are very important, researchers and risk modelers have conceived and developed more advanced methodologies to address such issues.

Among them, Dynamic Fault Tree (DFT) (Čepin and Mavko, 2002) is one of the most famous as it is able to address temporal (Ammar et al., 2019) and interdependencies among the system components with the aid of the so-called dynamic gates. Other researchers (Raiteri et al., 2004; Codetta Raiteri, 2011) extended the original DFT formalism to cope with repairable events and generalized repairable policies. As shown in (Yuge, Tamura and Yanagi, 2012) an approach for dealing with Repairable Dynamic Fault Tree is by combining the basic event along with its repair process using the concept of renewal processes instead of the commonly used Markov chains. Boolean Logic Driven Markov Process (BDMP) is an equivalent formalism that combines Fault Trees and Markov processes (Bouissou, 2007). This latter is very powerful because it has no

limit in terms flexibility of modeling very complex scenarios, although its resolution can become cumbersome and resort into a well-known issue, called state-space explosion, which require numerical and simulation approach to mitigate it.

Starting from the modeling proposed in (Su and Fu, 2014a), in this paper the SHyFTOO library is used to analyse the reliability of a wind turbine with the main advantage to avoid any further transformation of the original model, like the Bayesian Network proposed in (Su and Fu, 2014a). Moreover, in order to increase the performance and accuracy of the SHyFTOO library, the simulation engine has been improved with the addition of a Simulink block able to handle the logic of Hybrid Basic Events of the system, which are defined in table 1. The choice of studying the wind turbine is made due to the fact that a great importance lies in the effect of availability of this system on the economical efficiency of power production. This system is affected by both internal aging and performance differentiation of the working environment, i.e., wind speed, which makes it a perfect case study for the subject of stochastic hybrid modelling of dynamic reliability.

The remainder of this paper is organized as follows. In the next section, a regard to the related work and more explanation about the relevance of the used technique and case study is provided. Section 3 presents the main information about the Hybrid Dynamic Fault Trees and of the SHyFTOO library. Section 4 discusses the case study of the wind turbine, showing the motivation and impact through the proposed modelling approach. Section 5 discusses the main results of the simulation and Section 6 draws the conclusions.

2. Literature Review

There is a vast amount of work around the usage and solution of the dynamic fault tree and the different modeling capabilities of this method, e.g., repairs, degradation and aging. Moreover, several tools have been developed to provide easier solution of the created model. Here, a review has been performed to represent the most relevant work

As it can be understood, the resolution of a Dynamic Fault Tree is not trivial because the structure function of such model cannot be obtained, like in Static Fault Tree, with the Boolean Algebra. Therefore, to solve Dynamic Fault Trees, three main methods can be used: (i) algebraic methods, (ii) conversion into an equivalent model and (iii) simulation. In (Merle et al., 2010; Merle, Roussel and Lesage, 2011) algebraic methods to address temporal priorities and perform a quantitative analysis of the dynamic gates are presented. But restorations are not easy to incorporate, and thus, such methodologies are limited. Another option, the conversion into an equivalent model, like Markov chains, can be doable if the original DFT meets some requirements, e.g., only components with

exponential failures to solve via Chapman-Kolmogorov equations. In a recent contribution (Aslansefat and LatifShabgahi, 2019), the use of nonexponential distributions has been discussed and tackled with a simplified hierarchical approach that, through a limited state-space constituted of five states, can be solved through the Semi-Markov Process theory. Unfortunately, the same paper does not provide further hints when repair-able components are involved in the model.

Among the previous methods, simulation seems to offer a greater modeling flexibility than other techniques as shown in (Durga Rao et al., 2009) where it was used to model and analyze complex critical systems, like a steam generator (Babykina et al., 2016), a flare gas recovery system (Khodayee, Chiacchio and Papadopoulos, 2021) and renewable power plants, for which failure and repairable logics de-pends also on the working and environmental conditions. In most of the RAMS problems, simulation frameworks adopt Monte Carlo algorithm to determine the reliability/availability of a system. In order to be effective, the Monte Carlo simulation has to perform multiple iterations to achieve the desired accuracy in terms of estimations. Therefore, the main issue is that it can become time-consuming in order to obtain accurate results.

In a previous paper (Chiacchio, Iacono, et al., 2020), a generalized simulation framework to model and simulate Repairable Dynamic Fault Trees coupled with physical equations is presented. Moreover, it sets the foundation for an extended powerful formalism, the Hybrid Dynamic Fault Trees (also known as Stochastic Hybrid Fault Tree Automaton, SHyFTA) that can be chosen when the failure/repair, maintenance policies (Arena, Roda and Chiacchio, 2021), degradation and aging of the system components depends on the physical process. For this class of models, a software library (SHyFTOO) to aid the design and the simulation has been proposed (Chiacchio, Aizpurua, et al., 2020). It has been coded in Matlab® and offers an easy integration with Simulink in order to simplify the modelling of the physical dynamic equations of a process. Dynamic equations incorporate changes in wind speed, belonging to the environmental impact on the reliability and performance which are modelled easily through our proposed tool. And the effects are studied with the advantages that are benefited from SHyFTOO.

There are recent some papers with the focus on the aging of the wind turbine and the effects on the functionality and its reliability. (Yang et al., 2021) considered the potential maintenance opportunities emerging from dynamic wind velocities and turbine operation conditions as an extension to the existing operations and maintenance framework. They create a cost-effective opportunistic maintenance by making the most out of unavoidable leisure times. Their proposed maintenance scheduling policies were

interwoven with operational age of the turbines. (Byrne et al., 2020) studied the performance deterioration with age of a wind turbine whose gear box actually reached the end of its life by analyzing the thirteen years of recorded data. A multi-variant support vector regression with gaussian kernel machine learning technique was used for the wind turbine performance control and monitoring which concluded that the results of this study do not conform well to the hypothesis that the aging degradation is linear in time. They used the same machine technique in (Astolfi, Byrne and Castellani, 2020) to compare two wind turbines in different wind speed regions and observed that different components' aging had different effect on the power production on each wind turbine.

3. Hybrid Dynamic Fault Trees

Hybrid Dynamic Fault Trees relax the rigid hypotheses of traditional RAMS methodologies, being able to consider numerous characteristics of complex systems, including changes on the working and environmental conditions, dependencies between process variables and stochastic events and interdependencies among the system components.

The construction of the failure model follows the well-known top-down approach that, starting from an undesired scenario, identifies the root causes and the combination of events that caused it. The root causes of a Fault Tree are called Basic Events. The combination of the Basic Events is handled by means of the gates that, for the Hybrid Fault Trees, are shown in Table 1. The mathematical formulation of Hybrid Dynamic Fault Trees can be found in (Chiacchio et al., 2016). Here, it is important to recall the main information about Dynamic Reliability so as to motivate the adoption of this type of simulation approach.

The reliability of a system is the probability that it can survive beyond the mission time, and it can be written as:





$$R(t) = P(S(t) > T_M) = 1 - \int_0^{T_M} f_S(t) dt \quad (1)$$

where S is a stochastic variable measuring the survival time of the system, T_M is the time of mission and $f_S(t)$ is the probability density function of the time to fail. Equation (1) is not general enough to consider the working and operational conditions in which the system operates because those are often variables that depend on the physical dynamics of the system.

Dynamic Fault Tree formalism does not offer, natively, a parametrization to include such variables in its modelling, as it is a pure stochastic methodology. For instance, the aging effect for modelling the real consumption during the system lifecycle is often modelled using a static Weibull probability density function (shape factor > 1.2). This is a coarse approximation, because it assumes a direct linear dependency with the mission time. This implies that the system operates continuously without any

interruption, but this is not true for the majority of the industrial processes, which are characterized by different events, such as stops, pauses and changes of working schedule.

Table 1. Gates of the Dynamic Fault Tree technique.

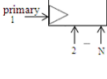
Name	Graphical Representation	Description
AND		This gate triggers if all the inputs fail
OR		This gate triggers as soon as one of its inputs fail
PAND		This gate triggers if all the inputs fail in the order from left to right
SPARE		This gate triggers if the primary inputs (p _i) which fail do not have a spare input (s _i) available to replace it
SEQ		This gate forces the inputs to fail in the order from left to right and triggers if all the inputs fail
FDEP		This gate models a failure dependency of the primary input to the secondary inputs. When the primary fails, the secondary inputs fail too.

A Hybrid Dynamic Fault Tree can tackle this issue by coupling to the variable time of the system components subjected to aging the following piecewise differential equation:

$$\frac{dL}{dt} = i_{on}$$

$$i_{on} = \begin{cases} 1, & \text{the component is switched on} \\ 0, & \text{the component is switched off} \end{cases} \quad (2)$$

where L represents the actual aging of a component. This differential equation states that the aging increases only when the component is working. Replacing the equation (2) into equation (1), the Dynamic Reliability of a component can be written as follows.

$$R(t) = P(S(L) > T_M) = 1 - \int_0^{T_M} f_S(L) dt \quad (3)$$

In a reliability formulation, the probability density function $f_S(L(t))$ of a component is assumed to be static and it is often modelled with the exponential distribution that characterize random independent failures. Hybrid Fault Tree allows to use the general equation of reliability

$$R(t) = e^{-\int_0^t h(\tau) d\tau} \quad (4)$$

In Eq. (4), $h(\tau)$ is the instantaneous dynamic failure rate of the component, and it can be formulated to

model its dependency with other components and other physical process variables. In other words, stochastic events can affect the dynamic evolution of a system and, thus, modifies its structure. For instance, a failure of a component is an event that can alter the working condition of another component (e.g., load sharing) and this dependency should be reflected in the formulation of Eq. (4). For instance, Figure 1 shows a Weibull probability density function that depends on the aging L and on a physical variable of the system process (T_e). In a Hybrid Fault Tree, a Basic Event characterized by a dynamic failure rate, or a dynamic probability density function is called Hybrid Basic Event. Thanks to this flexibility, the Hybrid Dynamic Fault Tree can be used to model more accurately than traditional techniques in those scenarios where the probability density function of an event has to change dynamically with the working or the operative conditions.

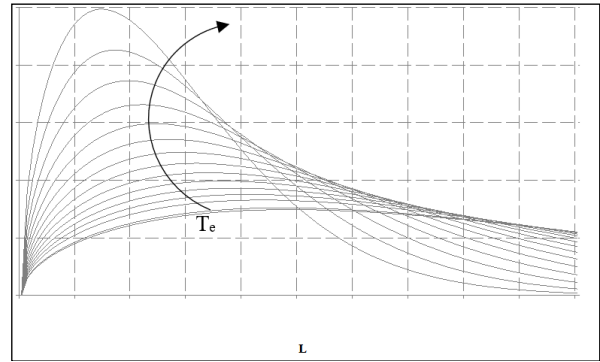

Figure 1. Weibull pdfs that vary with an external parameter (T_e).

3.1. SHyFTOO Library

The beauty of Hybrid Dynamic Fault Trees is to keep simple for risk practitioners the designing of the system. This is achieved through the well-known gates and the top-down design approach, which accelerates the failure modelling process. However, the actual modelling and resolution, including the physical equations embedded in the failure rates, may not be easy to achieve without a computerized design tool that assists with these modelling activities.

In (Chiacchio, Aizpurua, et al., 2020) it has been presented a toolbox library, the SHyFTOO, which can be used to model and solve a Hybrid Dynamic Fault Tree. The SHyFTOO Library has been developed under the Matlab® environment. Moreover, it can be integrated with the Simulink toolbox to make simple the modelling of physical dynamic equations and build complex multistate logics. The SHyFTOO library supports the gates shown in Table 1. The other relevant settings available with the SHyFTOO toolbox are the following:

- Multistate components: the dyadic hypothesis is relaxed on behalf of components which can present several statuses of functioning.

- Repeated components: a component can be present in different section of the same fault tree.
- Repairable components: components can be characterized by a repair transition.
- Cascading of dynamic gates: no limitation of nesting of gates, including the dynamic ones.
- Failure Gate: this is an attribute that can characterize any generic gate. It is a powerful concept that is described in detail in the next subsection.

The resolution algorithm is based on an optimized Monte Carlo simulation that combines time-driven and discrete-event simulation. In this latest release, a Simulink block has been added in order to stop an iteration and avoid expensive computational expenses when the metrics to compute is the reliability of the system.

3.2. Failure Gates

An important feature of SHyFTOO is the concept of failure gate that enables the calculation of the reliability of a system with or without repairable components and the instantaneous and steady-state availability. With the aid of Figure 2, it is possible to explain the concept of failure gate using as example an AND Gate with two inputs (A, B), for which the reachability graph is presented for three different types of scenarios: (a) reliability, (b) reliability with restoration and (c) availability. The bold statuses correspond with the failure state of the AND gate.

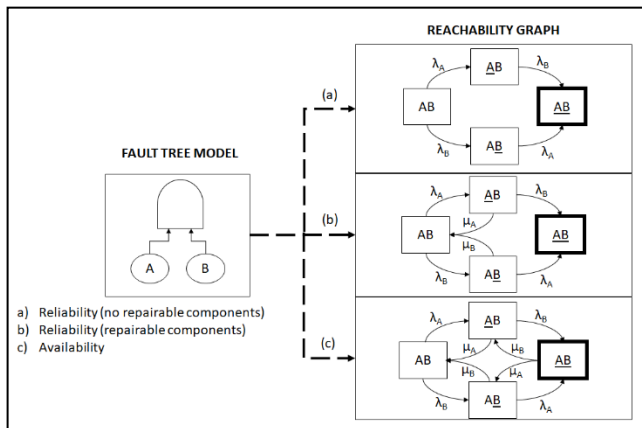

Figure 2. Reachability graph of an AND Gate (the failure state is the one with the bold contour).

In the case (a), the failure state is non-reversible. This is because both the components are not repairable. In the case (b) the restoration of a component is allowed as long as the gate has not triggered. This type of gate allows to model an AND gate with repairable components and to compute the reliability of the gate. In the last case (c), restorations are allowed any time also in the status of failure. This type of modelling is

then used to evaluate the instantaneous availability of the AND gate.

The main limitations during the construction of a Fault Tree model are thereby listed:

- Spare events (gates or basic events) can be shared only among SPARE Gates;
- The input of a SEQ cannot be repeated in other gates (this would break the logic of the SEQ gate).

4. Case Study

The Hybrid Dynamic Fault Tree model of the wind turbine has been inspired by a previous work (Su and Fu, 2014a) that used Bayesian Network to solve it. A wind turbine is made up of several subsystems and components, as shown in Figure 3 (Arabian-Hoseynabadi, Tavner and Oraee, 2010). The main components list is displayed in Table 2.

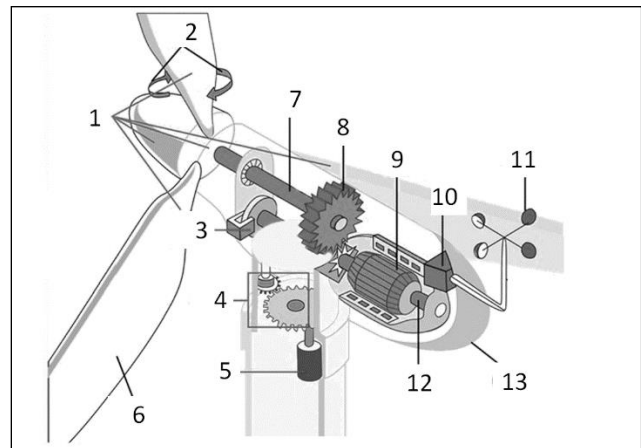

Figure 3. Main subassemblies of a wind turbine.

Table 2. List name of the main subassemblies and components.

ID	Description	ID	Description
1	Rotor	8	Gearbox
2	Pitch System	9	Generator
3	Brake	10	Controller
4	Yaw Drive	11	Anemometer
5	Yaw Motor	12	High-Speed Shaft
6	Blades	13	Nacelle
7	Low-Speed Shaft		

The simplified fault tree schema of a generic wind turbine is shown in Figure 4, whereas the Basic Events and the related properties are resumed in Table 3. This model will be used as case study to analyse the reliability of the wind turbine. As depicted in the fault tree, the main subassemblies are the gearbox, the blades, the generator, the electrical subsystem, the converter, the yaw assembly, the pitch assembly, the brake assembly, and the hydraulic assembly.

The brake assembly is constituted by the air brake and by the mechanical brake and its failure occurs if both these components fail; therefore, it can be modelled

with the AND gate. As for the other relationships, it can be seen that the fault of any subassemblies turns in the failure of the WTG, therefore the other gates must be represented by means of the OR gate.

Table 3. Probability Density Functions of the main WTG Subassemblies (Su and Ye-qun Fu, 2014).

ID	Description	pdf ($0 < v \leq 20\text{m/s}$)	pdf ($> 20\text{m/s}$)
BE1	Generator Fault	Wei(76000;1.2)	Wei(76000;1.2)
BE2	Gearbox Fault	Wei(12300;1.05)	Wei(12300;1.05)
BE3	Blade Fault	Nor(42000;663)	Nor(42000;663)
BE4	Electrical System Fault	Wei(35000;1.5)	Wei(35000;1.5)
BE5	Converter System Fault	Exp(1/45000)	Exp(1/45000)
HBE6	Pitch Assembly Fault	Nor(84534;506)	Nor(14089;506)
HBE7	Yaw Assembly Fault	Exp(1/65000)	Exp(1/8125)
HBE8	Hydraulic Assembly Fault	Wei(66000;1.3)	Wei(33000;1.3)
HBE9	Air Brake Fault	Exp(1/100000)	Exp(9/500000)
HBE10	Mechanical Brake Fault	Exp(1/120000)	Exp(1/30000)

On a first observation of the fault tree schema of Figure 4, it is possible to agree that it is a very simple Static Fault Tree that can be solved with the Boolean Algebra rules. Therefore, for the evaluation of this case study, what are the reasons for us to trouble with a Hybrid Dynamic Fault Tree? The answer to this question is still shown in Table 3: as discussed in (Su and Fu, 2014a), the failure probability density function of the components depends on an external variable, the wind speed.

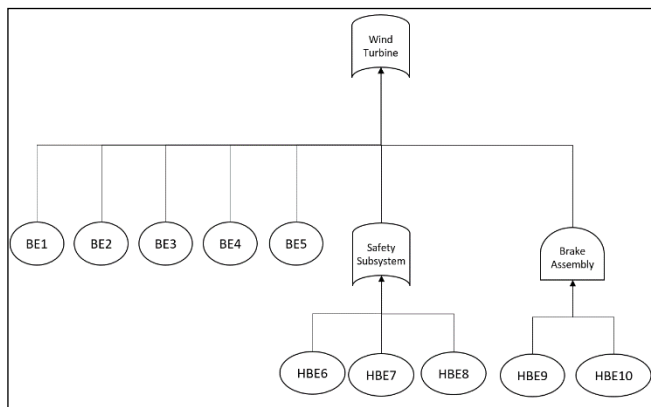

Figure 4. Fault Tree of the Wind Turbine Generator.

This latter is the most important physical variable for the operations of the wind turbine and, as it can be seen, the threshold value of 20 m/s defines a limit between two different failure probability density functions, for each component of the wind turbine. In the paper of (Su and Fu, 2014a), the reliability technique to analyse this behaviour was to resort into a Bayesian network, whereas in this manuscript it is enough to use an Hybrid Basic Event and to define the condition (the threshold value) to trigger from one pdf

to the other.

Moreover, in this paper, the real aging of the WTG has been considered by exploiting the power curve of Figure 5 (Dupont, Koppelaar and Jeanmart, 2018) that rules the switching on of the WTG, when the wind speed is higher than the cut-in value. Therefore, this modeling can be achieved linking the cut-in value to the piecewise differential equation of the aging (eq. 3) as follows:

$$i_{on} = \begin{cases} 1, & v_{wind} \geq v_{cut-in}, \text{ WTG is ON} \\ 0, & v_{wind} < v_{cut-in}, \text{ WTG is OFF} \end{cases} \quad (5)$$

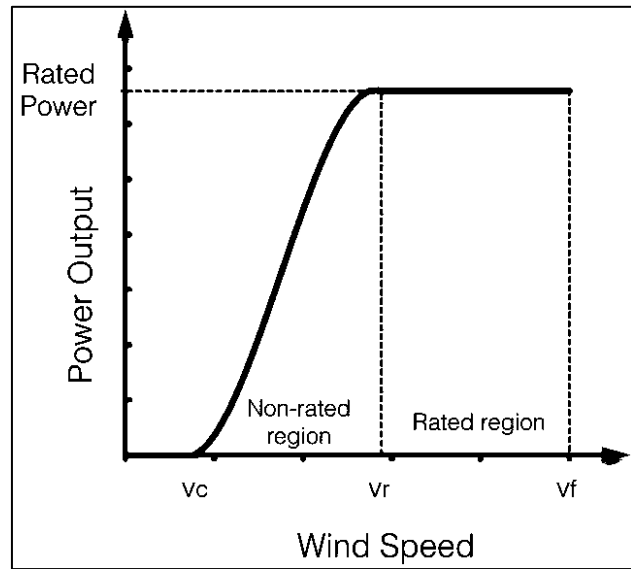

Figure 5. Generic power curve of a WTG (Dupont, Koppelaar, and Jeanmart, 2019).

5. Simulation and Results

The wind speed physical variable used in the proposed case study has been taken from a real historical time-series of a wind site located in Sicily, for the year 2012 (Figure 6).

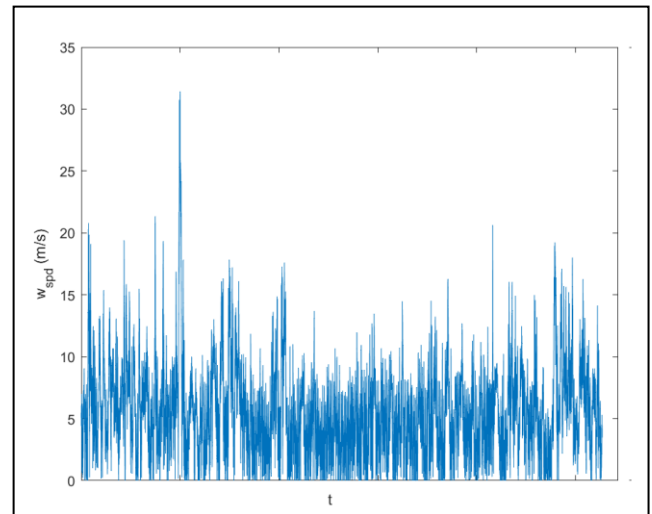

Figure 6. Wind speed historical time-series, Sicily (2012).

The acquisition of this data has been achieved using a SCADA of a second level of the main anemometer of the wind field. The time-step of the data is of 10 minutes. This value will be used also for the integration time-step, $\Delta\tau$, of the simulation of the Hybrid Dynamic Fault Tree, coded with the SHyFTOO library. For the Hybrid Basic Event, the instantaneous evaluation of the working condition of a subassembly is performed by the discrete integration of eq. 4, comparing it with a random uniform sample value, ψ in $[0, 1[$, as shown in the following inequality:

$$\psi < 1 - e^{-h(\tau)\Delta\tau} \quad (6)$$

The $v_{\text{cut-in}}$ that switches the WTG on has been set to 5 m/s. The simulation has been set in order to perform 10^4 iterations.

Figure 7 shows the comparison of the results of four different scenarios: a Static Fault Tree under a conservative scenario assuming the failure behaviour of the components when the wind speed is higher than 20 m/s, a Static Fault Tree in the best case scenario when the wind speed is between 5 and 20 m/s, the Static Fault Tree using the weighted average of the wind speed and the Hybrid Fault Tree that considers the aging of the turbines, the cut-in activation and the dynamic change of the failure behaviour of the system components with respect to the wind speed.

As shown in Figure 7, the reliability of the WTG evaluated with the HDFT is higher than the best-case scenarios and of the weighted average, but it is lower than the worst-case scenario, as it could be expected. This result is interesting because it demonstrates the important influence of the physical working conditions on the WTG reliability which, with traditional techniques, cannot be obtained.

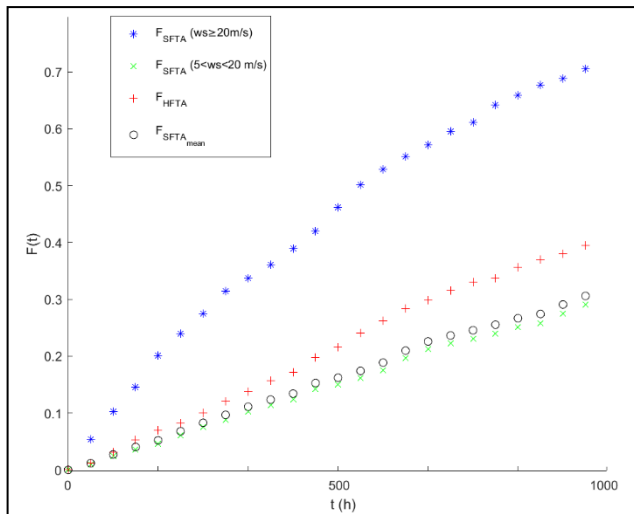

Figure 7. Comparison of the WTG unreliability with various methods.

6. Conclusions

The reliability assessment of a complex system is not an easy task because the modelling and the resolution of a stochastic model requires (i) the study of the system process, (ii) its mapping into an appropriate formalism able to capture the relevant characteristics of the system and of the related process, and (iii) the quantitative resolution of the model. To this end, literature has developed several techniques that go under the umbrella of the Reliability, Availability, Maintenance and Safety (RAMS) Engineering.

In this paper the main limitations of traditional RAMS methodology have been discussed claiming that a more accurate reliability assessment requires a RAMS model to consider not only the system logic of failure but also the influences of the working, the operative and the environmental conditions into the system itself and its subparts. Afterwards, a more recent methodology, the Hybrid Dynamic Fault Tree has been presented with the aim to explain what original concepts it brings to improve the accuracy of the RAMS model.

The use case of a Wind Turbine generator has been chosen in order to demonstrate what practical reasons can motivate the use of a Hybrid Dynamic Fault Tree (HDFT) model over the Static Fault Tree and traditional Dynamic Fault Tree models. As it was shown, past literature describes already many similar use cases with other methodologies, and it appeared clear that a more realistic reliability assessment requires the modelling by means of a richer methodology. Therefore, the main novelty of the proposed reliability analysis has been the inclusion of the wind speed, an independent exogenous physical variable, as a trigger in the Hybrid Basic Events of the HDFT model that, according to (Su and Fu, 2014a) influences the parameters of the probability density of failures of the components and of the system aging.

The simulations performed show that the HDFT brings to a slightly different results than the corresponding Static Fault Tree without the physical wind variable and this encourages the adoption of these new class of methodologies when such influences should not be neglected.

In a future work, the integration of the Maintenance Box (Arena, Roda and Chiacchio, 2021) along with advanced Artificial Intelligence methodologies will be proposed to evaluate the most advantageous maintenance policy of a wind power plant.

Fundings

This paper belongs to a research path funded by University of Catania (PIA.CE.RI. 2020–2022 Linea 2—GOSPEL Project—Principal investigator A. Costa - Code 61722102132).

References

- Ammar, M. et al. (2019) "Towards an Accurate Probabilistic Modeling and Statistical Analysis of Temporal Faults via Temporal Dynamic Fault-Trees (TDFTs)," *IEEE Access*, 7, pp. 29264–29276. Available at: <https://doi.org/10.1109/ACCESS.2019.2902796>.
- Arabian-Hoseynabadi, H., Tavner, P.J. and Oraee, H. (2010) "Reliability comparison of direct-drive and geared-drive wind turbine concepts," *Wind Energy*, 13(1), pp. 62–73. Available at: <https://doi.org/10.1002/we.357>.
- Arena, S., Roda, I. and Chiacchio, F. (2021) "Integrating modelling of maintenance policies within a stochastic hybrid automaton framework of dynamic reliability," *Applied Sciences (Switzerland)*, 11(5), pp. 1–18. Available at: <https://doi.org/10.3390/app11052300>.
- Aslansefat, K. and Latif-Shabgahi, G.R. (2019) "A Hierarchical Approach for Dynamic Fault Trees Solution through Semi-Markov Process," *IEEE Transactions on Reliability*, 69(3), pp. 986–1003. Available at: <https://doi.org/10.1109/TR.2019.2923893>.
- Astolfi, D., Byrne, R. and Castellani, F. (2020) "Analysis of wind turbine aging through operation curves," *Energies*, 13(21). Available at: <https://doi.org/10.3390/en13215623>.
- Babykina, G. et al. (2016) "Modeling and simulation of a controlled steam generator in the context of dynamic reliability using a Stochastic Hybrid Automaton," *Reliability Engineering and System Safety*, 152, pp. 115–136. Available at: <https://doi.org/10.1016/j.ress.2016.03.009>.
- Bouissou, M. (2007) "A generalization of Dynamic Fault Trees through Boolean logic Driven Markov Processes (BDMP)®," in *Proceedings of the European Safety and Reliability Conference 2007, ESREL 2007 - Risk, Reliability and Societal Safety*, pp. 1051–1058.
- Byrne, R. et al. (2020) "A study of wind turbine performance decline with age through operation data analysis," *Energies*, 13(8). Available at: <https://doi.org/10.3390/en13082086>.
- Calixto, E. (2013) "Chapter 6 - Reliability and Safety Processes BT - Gas and Oil Reliability Engineering," in *Gas and Oil Reliability Engineering*, pp. 421–496. Available at: <http://www.sciencedirect.com/science/article/pii/B978012391914400006X> (Accessed: October 6, 2021).
- Čepin, M. and Mavko, B. (2002) "A dynamic fault tree," *Reliability Engineering and System Safety*, 75(1), pp. 83–91. Available at: [https://doi.org/10.1016/S0951-8320\(01\)00121-1](https://doi.org/10.1016/S0951-8320(01)00121-1).
- Chiacchio, F. et al. (2011) "Dynamic fault trees resolution: A conscious trade-off between analytical and simulative approaches," *Reliability Engineering and System Safety*, 96(11), pp. 1515–1526. Available at: <https://doi.org/10.1016/j.ress.2011.06.014>.
- Chiacchio, F. et al. (2016) "SHyFTA, a Stochastic Hybrid Fault Tree Automaton for the modelling and simulation of dynamic reliability problems," *Expert Systems with Applications*, 47, pp. 42–57. Available at: <https://doi.org/10.1016/j.eswa.2015.10.046>.
- Chiacchio, F., Iacono, A., et al. (2020) "A general framework for dependability modelling coupling discrete-event and time-driven simulation," *Reliability Engineering and System Safety*, 199. Available at: <https://doi.org/10.1016/j.ress.2020.106904>.
- Chiacchio, F., Aizpurua, J.I., et al. (2020) "SHyFTOO, an object-oriented Monte Carlo simulation library for the modeling of Stochastic Hybrid Fault Tree Automaton," *Expert Systems with Applications*, 146. Available at: <https://doi.org/10.1016/j.eswa.2019.113139>.
- Codetta-Raiteri, D. (2011) "Integrating several formalisms in order to increase fault trees modeling power," *Reliability Engineering and System Safety*, 96(5), pp. 534–544. Available at: <https://doi.org/10.1016/j.ress.2010.12.027>.
- Dupont, E., Koppelaar, R. and Jeanmart, H. (2018) "Global available wind energy with physical and energy return on investment constraints," *Applied Energy*, 209, pp. 322–338. Available at: <https://doi.org/10.1016/j.apenergy.2017.09.085>.
- Durga Rao, K. et al. (2009) "Dynamic fault tree analysis using Monte Carlo simulation in probabilistic safety assessment," *Reliability Engineering and System Safety*, 94(4), pp. 872–883. Available at: <https://doi.org/10.1016/j.ress.2008.09.007>.
- Khodayee, S.M., Chiacchio, F. and Papadopoulos, Y. (2021) "A novel approach based on stochastic hybrid fault tree to compare alternative flare gas recovery systems," *IEEE Access*, 9, pp. 51029–51049. Available at: <https://doi.org/10.1109/ACCESS.2021.3069807>.
- Merle, G. et al. (2010) "Probabilistic algebraic analysis of fault trees with priority dynamic gates and repeated events," *IEEE Transactions on Reliability*, 59(1), pp. 250–261. Available at: <https://doi.org/10.1109/TR.2009.2035793>.
- Merle, G., Roussel, J.M. and Lesage, J.J. (2011) "Dynamic fault tree analysis based on the structure function," in *Proceedings - Annual Reliability and Maintainability Symposium*. Available at: <https://doi.org/10.1109/RAMS.2011.5754452>.
- Raiteri, D.C. et al. (2004) "Repairable Fault Tree for the automatic evaluation of repair policies," in *Proceedings of the International Conference on*

Dependable Systems and Networks, pp. 659–668.
Available at:
<https://doi.org/10.1109/dsn.2004.1311936>.

Su, C. and Fu, Y.Q. (2014a) “Reliability assessment for wind turbines considering the influence of wind speed using bayesian network,” *Eksploatacja i Niezawodnosc*, 16(1), pp. 1–8.

Su, C. and Fu, Y.Q. (2014b) “Reliability assessment for wind turbines considering the influence of wind speed using bayesian network,” *Eksploatacja i Niezawodnosc*, 16(1), pp. 1–8. Available at: <https://www.infona.pl/resource/bwmeta1.element.baztech-56b87a18-1bde-4fab-a434-4d0ac2022a63> (Accessed: July 20, 2022).

Yang, L. et al. (2021) “Operations & maintenance optimization of wind turbines integrating wind and aging information,” *IEEE Transactions on Sustainable Energy*, 12(1), pp. 211–221. Available at: <https://doi.org/10.1109/TSTE.2020.2986586>.

Yuge, T., Tamura, N. and Yanagi, S. (2012) “Repairable fault tree analysis using renewal intensities,” in *Quality Technology and Quantitative Management*, pp. 231–241. Available at: <https://doi.org/10.1080/16843703.2012.11673289>.